

# SPECIFICATIONS

# GeoTag

GENERAL	
Operating Range	1000 m
Positioning accuracy	0.2 m typical after processing
Operating Frequency Range	35 kHz - 48 kHz
Max boat speed	5 knots
Number of Unique Addresses	10230
Available tests	Before deployment : acoustic telemetry test and battery level
TRANSPONDER	
Depth rating	500 m
Battery life (Alkaline)	6 months typical in operation
Weight	1 kg in air, 0.3 kg in water
Dimensions	370 mm x 60 mm
TRANSCIVER	
Transceiver user link	USB with junction box
Transceiver power supply	+90 VAC / +230 VAC with junction box
Weight	4.4 kg in air, 2.5 kg in water
Dimensions	340 mm x 100 mm
ENVIRONMENT	
Operating temperature	Transponder & transceiver : -20°C / +60°C
	PTE : -10°C / +60°C

Note: Sercel reserves the right to change its specifications without prior notice. All specifications are typical at 20°C

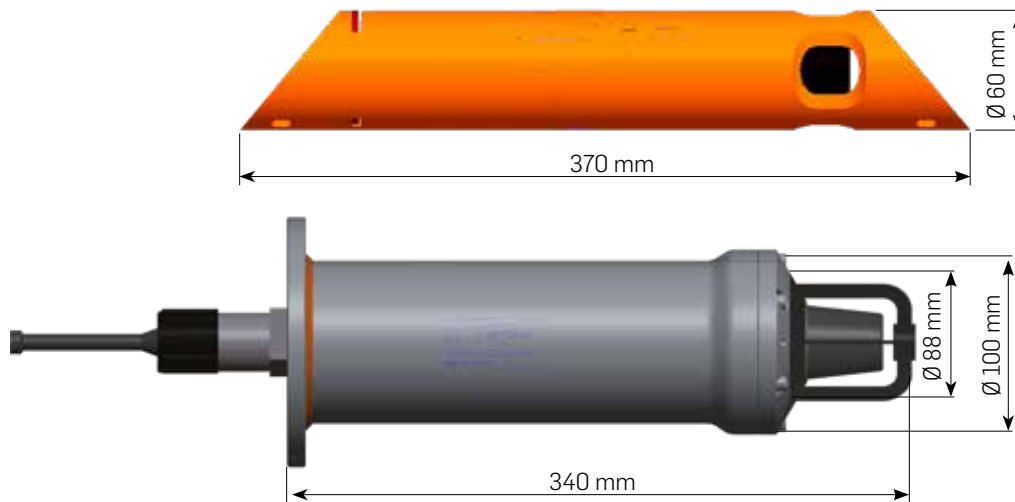

## SERCEL - FRANCE

16 rue de Bel Air - B.P. 30439 - 44474 CARQUEFOU Cedex  
 Téléphone : (33) 2 40 30 11 81  
 E-mail : sales.nantes@sercel.com  
 SAS au capital de 25 000 000 €  
 Siège Social : 16 rue de Bel Air - 44470 CARQUEFOU  
 378.040.497 R.C.S. Nantes Code APE 2651B

## SERCEL INC. - U.S.A.

17200 Park Row  
 Houston, Texas 77084  
 Telephone : (1) 281 492 6688  
 E-mail : sales.houston@sercel.com

sercel.com